

A、SCOPE 范围

This specification applies speaker, **KLS3-YS01A-27MM-8R0.5W**

B、SPECIFICATION 规格

(GENERAL)		
1	Size	$\Phi 27\text{mm} \times 5.0\text{mm}$
2	Power Rating	RATED POWER INPUT 0.5W MAX POWER INPUT 1.0 W
3	Impedance	8 Ohm $\pm 15\%$ at 1kHz 1.0V
4	Resonance Freq	580Hz $\pm 20\%$ at 1.0V
5	S.P.L	95dB ± 3 dB/0.1W/0.1m at 800Hz,1000Hz, 1200Hz,1500Hz average
6	Response	Fo—8 KHz, deviation -10dB max.
7	Distortion	5% max, at 1kHz 0.5W
8	Magnet	Nd-Fe-B ($\Phi 9.5\text{mm} \times 1.5\text{mm}$)
9	Operation Test	Must be normal at program source 1.41V
10	Polarity	When a positive D.C voltage is applied to the terminal Marked(+)or red the diaphragm should move to the front.
11	Terminal Strength	Capable of withstand a 500g load for 3sec. Without resulting in any damage or rejection.
12	Terminal Soldering Test	Speaker shall continue to operate after 10 sec. Stabilization test condition Suppling lead wire and solder on the terminal board and maintaining for 2seconds at temperature of 290—320 $^{\circ}$ c by hand iron
13	Appearance	Should not exist any kind of obstacle to be harmful to normal operation, not any remarkable damages, cracks, rust and distortions which may cause malfunction.
14	Marking	
15	Envirnmental Protection Regulation	ROHS



NINGBO KLS ELECTRONIC CO.,LTD.

C、 TYPICAL FREQUENCY RESPONSE CURVE 频率响应曲线



D、 MEASUREMENT CIRCUIT 测量线路

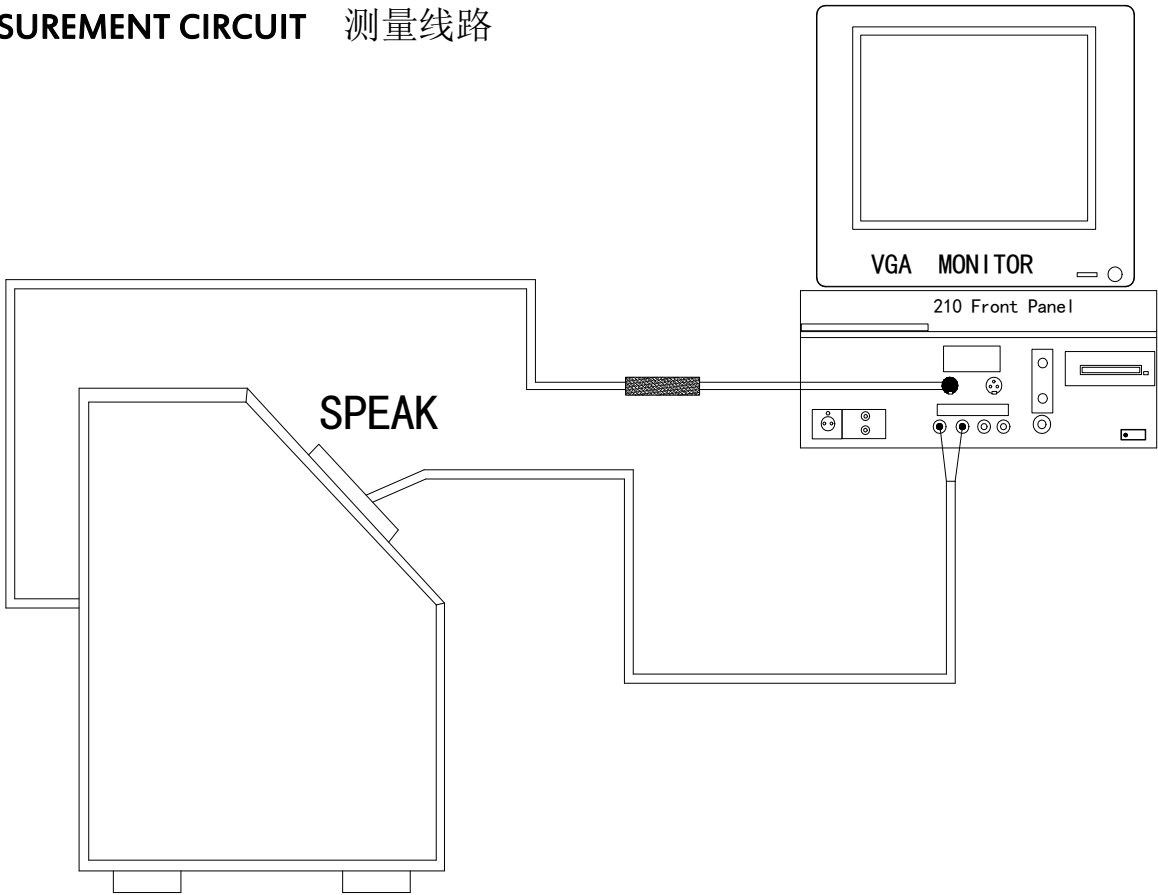

测试专用箱



NINGBO KLS ELECTRONIC CO.,LTD.

E、MECHANICAL CHARACTERISTICS 机械特性

NO	Item	Test condition	Evaluation standard
1	Vibration Test	Speaker shall be measured after being applied vibration of amplitude of 1.5mm with 10 to 55Hz band of vibration frequency to each of 3 perpendicular directions for 2 hours.	No obstacle to be harmful to normal operation ; Damages,cracks,rusts and distortions. Should not be audible at
2	Drop Test	Drop the speakers contained in normal box onto the board 40mm thick 10 times from the height of 75cm	1.41V sine wave between FO~5.0kHz

F、ENVIRONMENTAL TEST 环境试验

No.	Item	Test conditions	Evaluation standard
1	High temp. test	After being placed in a chamber at +55°C for 96 hours.	Being placed for 6 hours at +25°C ,receiver shall be measured. No obstacle to be harmful to normal operation ;damages, cracks, rusts and distortions, should not be audible at 1.41Vsine wave between Fo~4.0KHz. S.P.L. deviation of unit should be within ±3dB.
2	Low temp. test	After being placed in a chamber at - 25°C for 96 hours.	
3	Humidity test	After being placed in a chamber at +40°C and 90±5% relative humidity for 96 hours.	
4	Temp. cycle test	<p>The part shall be subjected to 6 cycles. One cycle shall be consist of :</p> <p style="text-align: center;">7.5hrs</p>	



NINGBO KLS ELECTRONIC CO.,LTD.

G、RELIABILITY TEST 信赖性试验

NO	Item	Test conditions	Evaluation standard
1	Load test	0.5W white noise is applied for 24 hours,at room temp.	Being placed for 1 hours at +25 °C ,speaker shall be measured,No obstacle to be harmful to normal operation;damages,cracks,rusts,etc.should not be audible at 1.41v sine wave between Fo~5.0KHz.Fo should meet intial one.S.P.L.deviation of unit should be within ± 3 dB

TEST CONDITION

Standard Test Condition : a) Temperature: +0.5~+35°C b) Humidity; 45~85% c) Pressure; 860-1060mbar
Judgement Test Condition: a) Temperature; +25 \pm 2°C b) Humidity; 60-70% c) Pressure; 860-1060mbar

H、APPEARANCE DRAWING 外观尺寸图

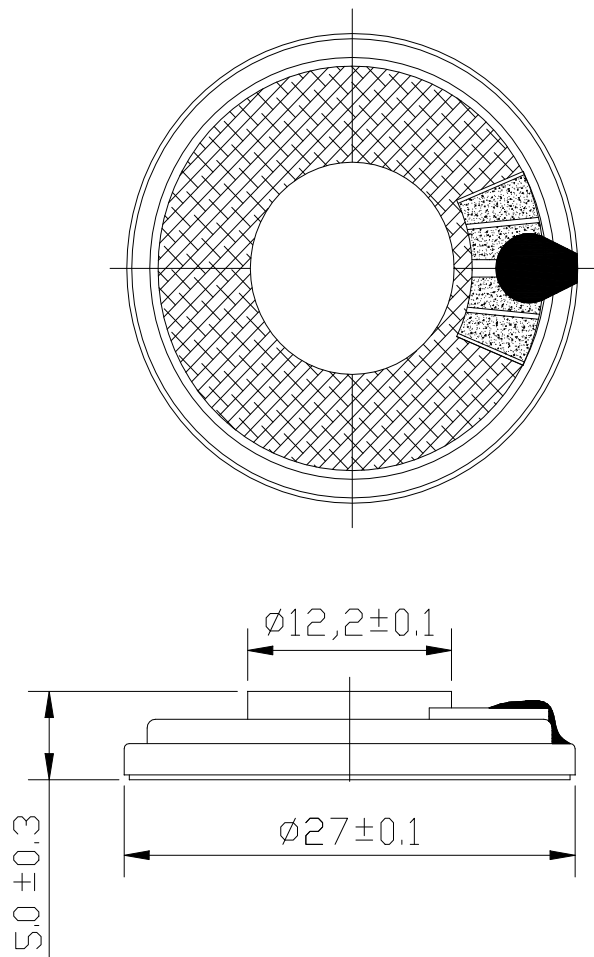

Unit: mm