

RoHS Compliance

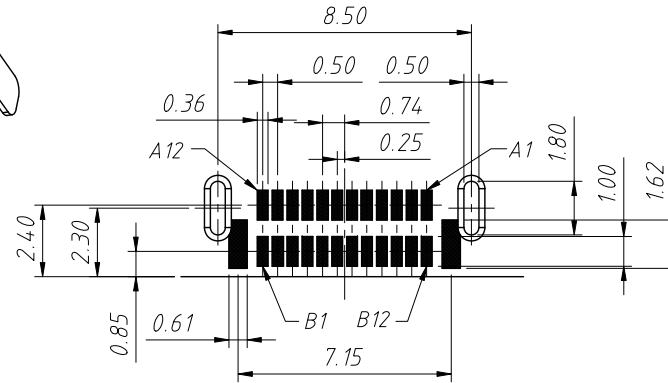
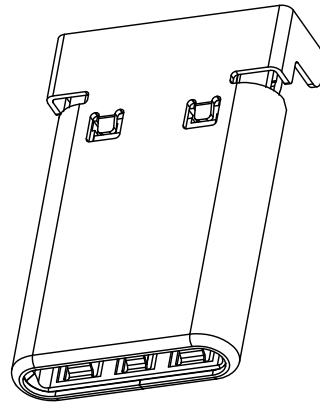
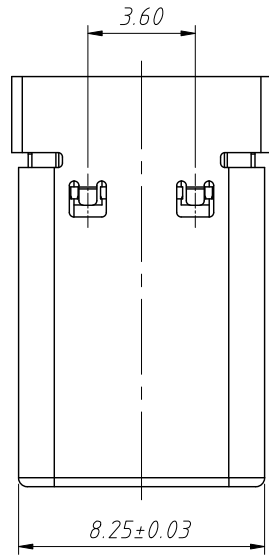

Recommend PCB Layout(T=0.80±0.05)
Component Side(General Tolerance:±0.05)

Material Specification:
Housing:High Temperature Resistant Plastic,UL94V-0
Contacts:Copper Alloy,
Gold Flash On Contact Area,
Gold Flash On Solder Area.
Under-Plating Ni 50u" Min.
Mid Plate:Stainless Steel
Front Shell:Stainless Steel,
Nickel Plating Over All.

Mechanical Performance:
Insertion Force:0.5~2.0kgf.
Removal Force:0.8kgf~2.0kgf.
Durability:10000 Cycles.

Electrical Performance:
Current Rating:3.0A
Voltage Rating:5.0V
Contact Resistance:40mΩ Max.
Insulation Resistance:100MΩ Min
Dielectric Withstand Voltage:
AC 100V For 1 Minute.

Environmental Performance:
Operating Temperature:-25°C~+85°C

Ir Reflow:
The Peak Temperature On The Board Shall
Be Maintained For 10 Seconds At 260°C.

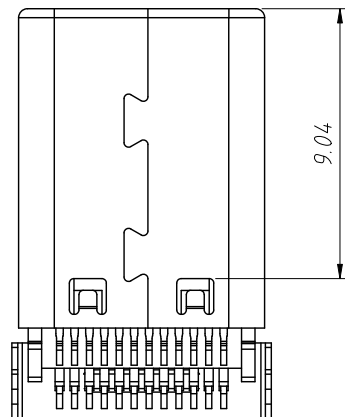
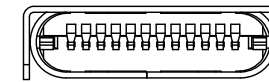
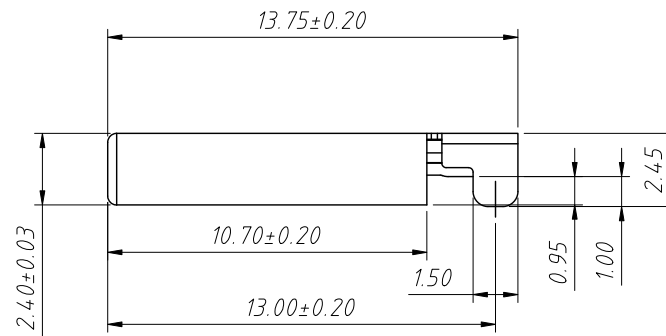
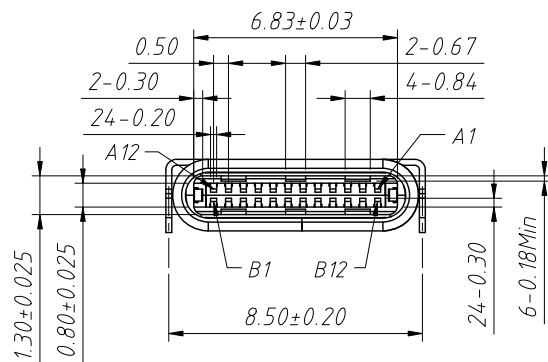

A1	GND	B12	GND
A2	SSTXP1	B11	SSRXP1
A3	SSTXN1	B10	SSRXN1
A4	VBUS	B9	VBUS
A5	CC1	B8	SBU2
A6	DP1	B7	DN2
A7	DN1	B6	DP2
A8	SBU1	B5	CC2
A9	VBUS	B4	VBUS
A10	SSRXN2	B3	SSTXN2
A11	SSRXP2	B2	SSTXP2
A12	GND	B1	GND
Pin	Signal Name	Pin	Signal Name

ANGLE TOLERANCE	PROJECTION	Description:	
±3°		USB Type-C connectors (Packing Reel)	
GENERAL TOLERANCE	UNITS	mm	KLS P/N:
x.x ±0.30	SHEET SIZE	A4	L-KLS1-5470-R
x.xx ±0.20	Draw:	Daniel	2022-07-15
x.xxx ±0.10	Check:	Daniel	2022-07-15

KLS
ELECTRONIC CO.,LTD.