

1 RoHS Compliance

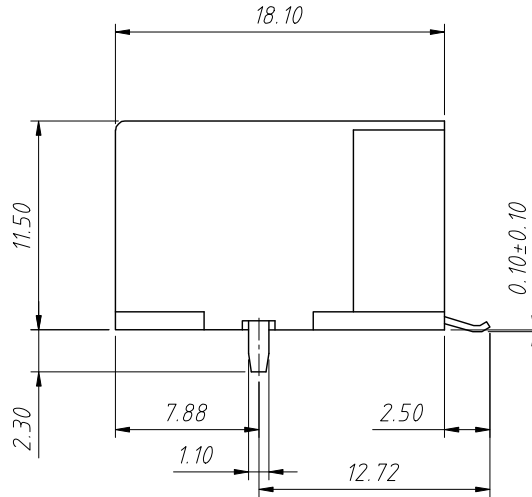
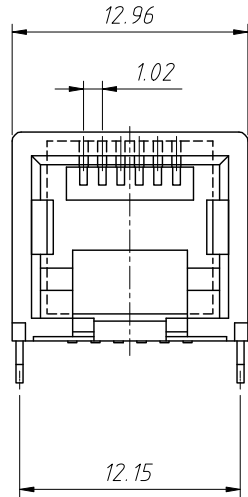

Electrical:

- 1.Voltage Rating:125VAC
- 2.Current Rating:1.5A
- 3.Contact Resistance:40mΩ Max.
- 4.Insulation Resistance:1000MΩ Min.@500VDC
- 5.Withstanding Resistance:1000VAC RMS.50Hz 1minute

Materials:

- 1.Housing:High Temp. Thermoplastic Flammability,UL 94V-0
- 2.Contact: Phosphor Bronze
- 3.Plating:Gold Plating over nickel in contact,
Tin Plating over nickel in solder area

Mechanical:

- 1.Durability:750 cycles Min.
- 2.PCB Retention pre-solder:1 LB Min.

Environmental:

1. Storage:-40°C ~ +85°C
2. Operation:-20°C ~ +75°C

P.C.B Layout (Top View)

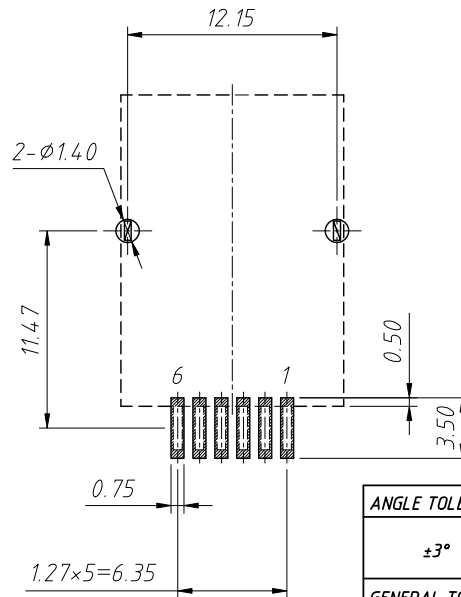
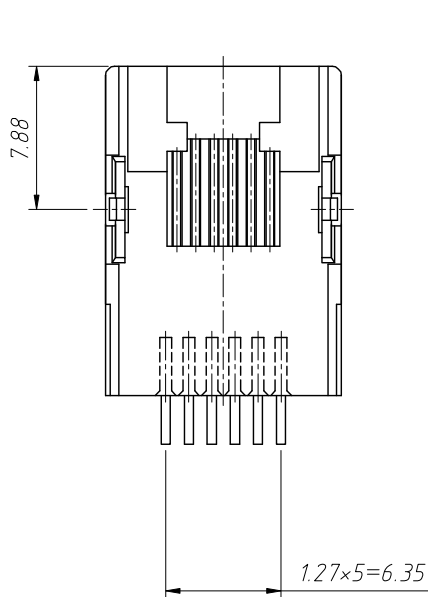

Order Information:

L-KLS12-SMT36-6P6C-N-XX-P

- L: RoHS
- SMT series
- Point No:6P6C
- Shield:N-Without Shield
- Plating:
- 01: 1u" Gold 02: 3u" Gold
- 03: 6u" Gold 04: 15u" Gold
- 05: 30u" Gold
- Packing:R-Reel P-Blister Tray

ANGLE TOLERANCE	PROJECTION	Description:	RJ12-6P6C SMD Jack Horizontal, Without Shielded
±3°			
GENERAL TOLERANCE	UNITS	mm	KLS P/N:
x.x ±0.30	SHEET SIZE	A4	L-KLS12-SMT36-6P6C-N-XX-P
x.xx ±0.20	Draw:Jenny	Daniel	2021-08-01
x.xxx ±0.10	Check:Daniel	Daniel	2021-08-01



NingBo KLS ELECTRONIC CO.,L TD.