

1
RoHS Compliance

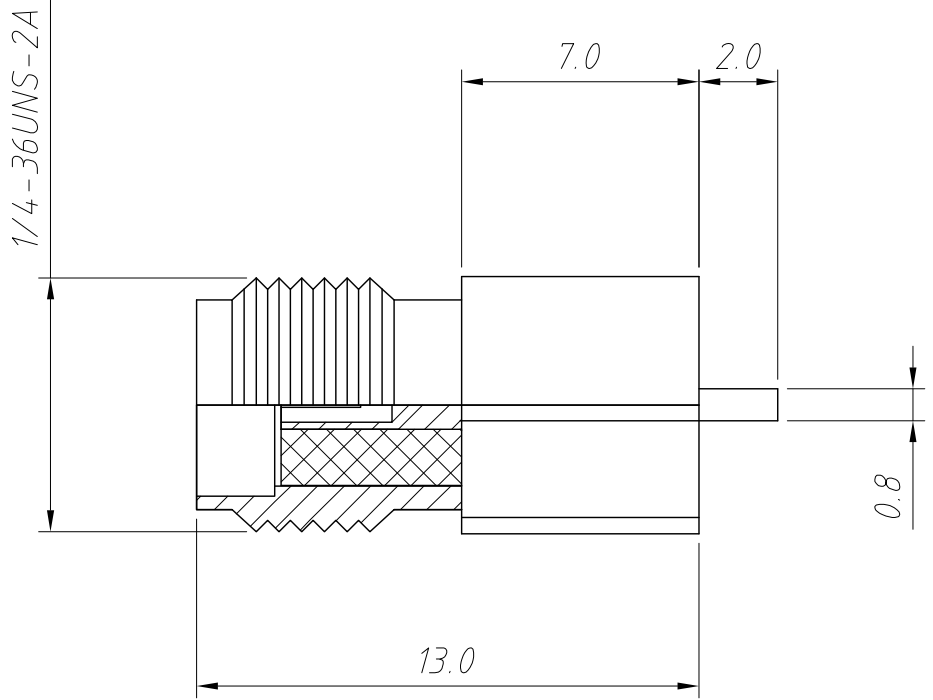

Order Information

L-KLS1-SMA054

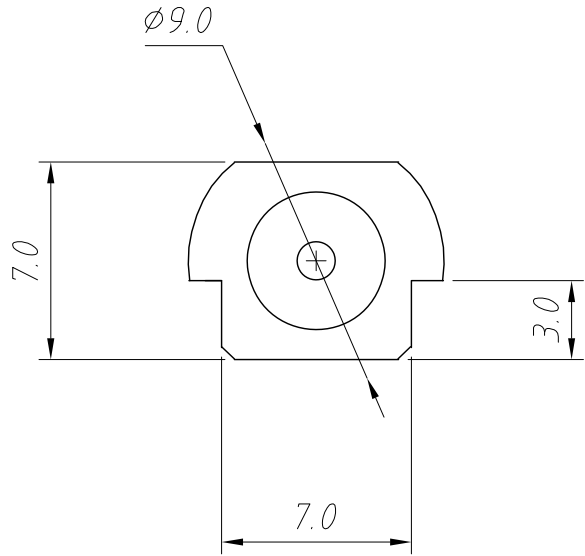
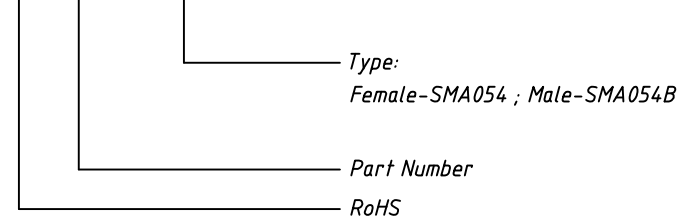

Electrical Specifications:
 Impedance: 50Ω
 Working frequency:0-3GHz
 Durability:500Cycles Min.

Material:
 Connector body: Brass ,Gold Plating

ANGLE TOLERANCE	PROJECTION	Description:	PCB Mount SMA Connector SMD (Jack,Female & Male ,50Ω)
±3°			
GENERAL TOLERANCE	UNITS	mm	KLS P/N:
x.x ±0.30	SHEET SIZE	A4	L-KLS1-SMA054 & L-KLS1-SMA054B
x.xx ±0.20	Draw:	Daniel	2020-11-11
x.xxx ±0.10	Check:	Daniel	2020-11-11

