

1 RoHS Compliance

MATERIAL:

Housing:LCP,UL 94-V0,Black
 Contact:Copper alloy,50u"min. Nickel plating
 Overall;100u" min.Tin on solder tail;
 Gold plating on contact area.
 Hook:Copper alloy,Nickel and Tin plating overall.

ELECTRICAL:

Contact Resistance: 25 mΩ Max.
 Insulation Resistance:1000 MΩ Min.
 Dielectric Withstanding Voltage: 500VRMS Min.

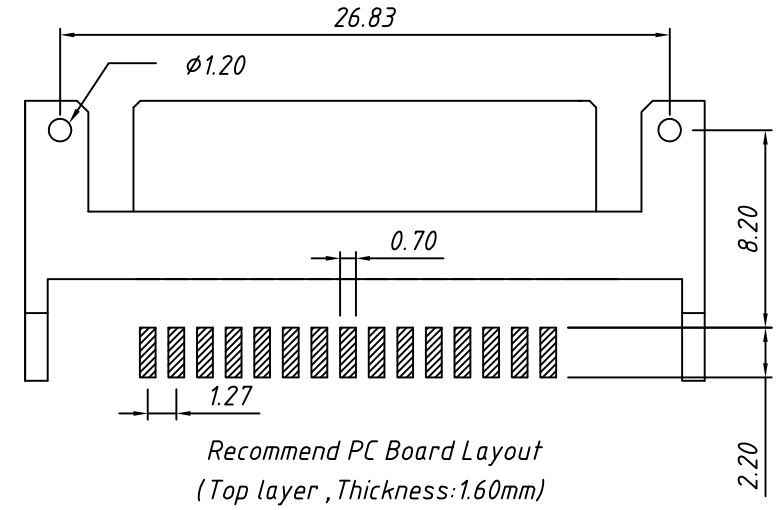
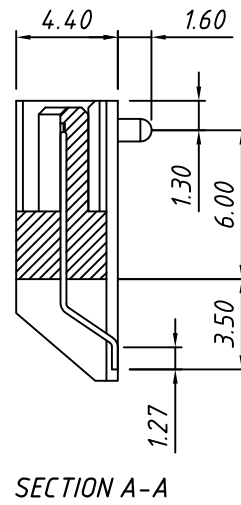
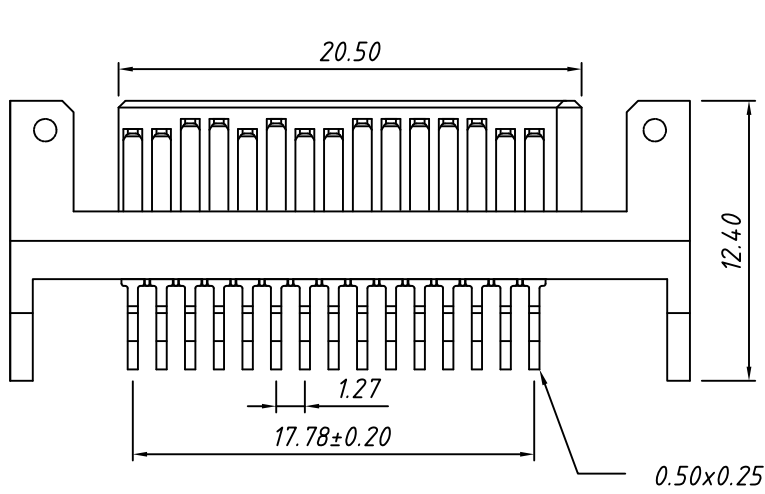
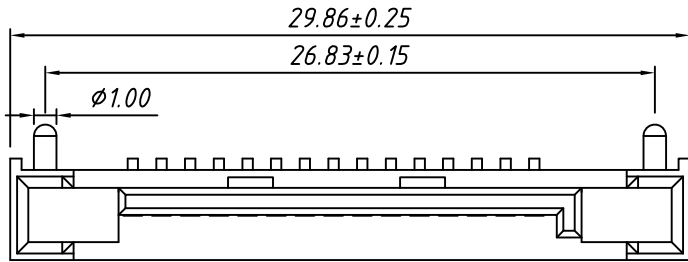

TOLERANCE		Description:	
.X ±0.30	PROJECTION		SATA Type A 15P Male Connector,SMD
.XX ±0.20	UNITS	mm	
.XXX ±0.10	SHEET	A4	
X. ±2°	Draw:	Daniel	KLS P/N: L-KLS1-SATA203
.X ±1°	Check:	Daniel	NingBo KLS ELECTRONIC CO.,LTD.
.XX ±0.5°	Date	2018-03-01	