

PCB LAYOUT

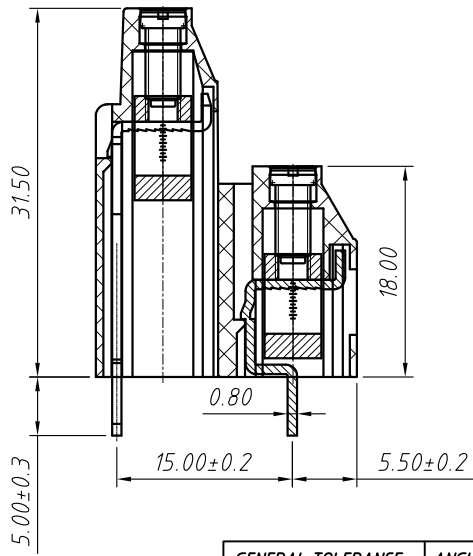
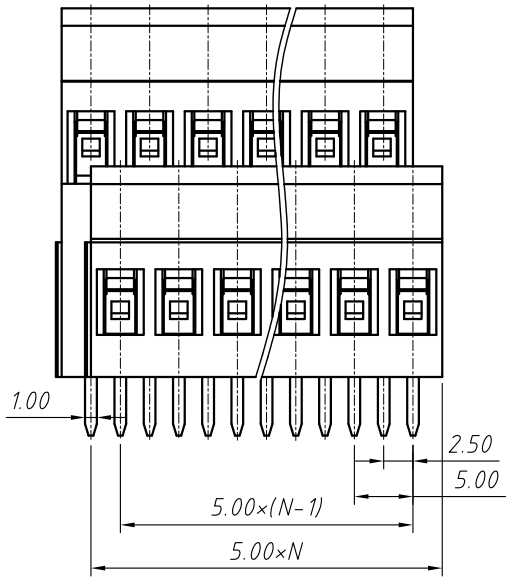

**Material**  
 Housing: PA66, UL94V-0  
 Clamp: Brass, Ni plated  
 Pin Header: Brass, Tin plated  
 Screw: M3.0, steel Zinc plated

**Electrical**  
 Rated voltage: 300V  
 Rated current: 20A  
 Contact Resistance: 20 mΩ  
 Insulation resistance: 500MΩ/DC500V  
 Withstand voltage: AC2000V / 1 min  
 Wire Range: 26~12AWG 2.5mm<sup>2</sup>

**Mechanical**  
 Temp. Range: -40 °C ~ +105 °C  
 Strip length: 6~7mm  
 Torque: 0.5Nm (4.5Lb.in)

**Order Information**

L-KLS2-130A-5.00-XXP-4S00

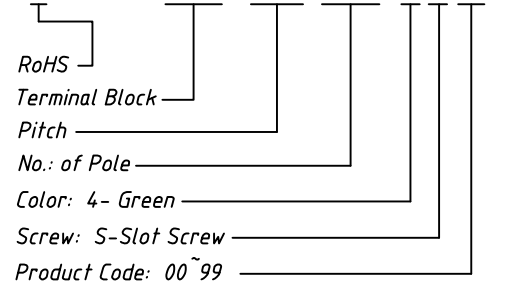

<b>GENERAL TOLERANCE</b>		<b>ANGLE TOLERANCE</b>		<b>Description:</b>	
X. ±0.60	.X ±0.38	.XX ±0.25	X. ±5°	.X ±3°	.XX ±2°
Draw by 2015-09-01			PROJECTION		 NingBo KLS ELECTRONIC CO.,L TD.
Check by 2015-09-15			UNITS mm		
SCALE			SHEET SIZE A4		
Screw CONN TERM Block 5.00mm				KLS P/N:	KLS2-130A-5.00-XXP-4S

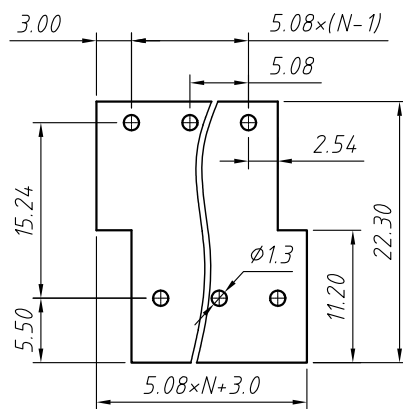
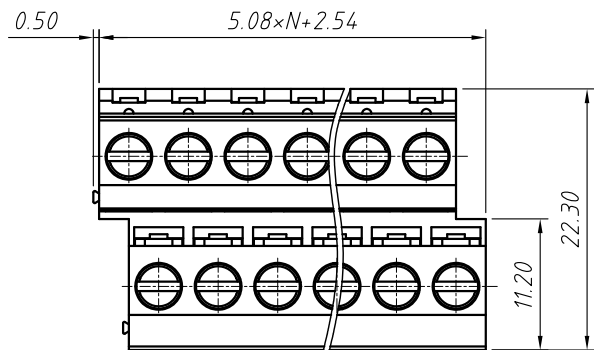

PCB LAYOUT

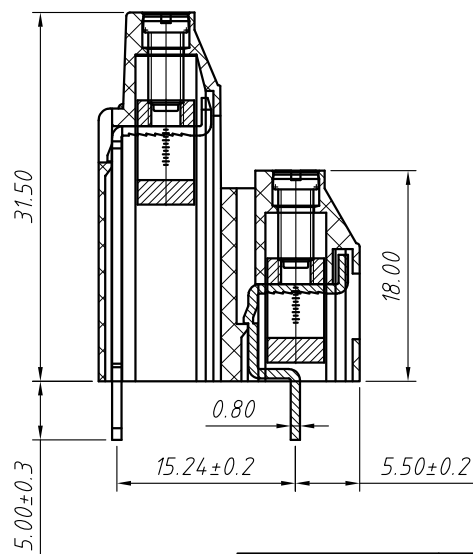
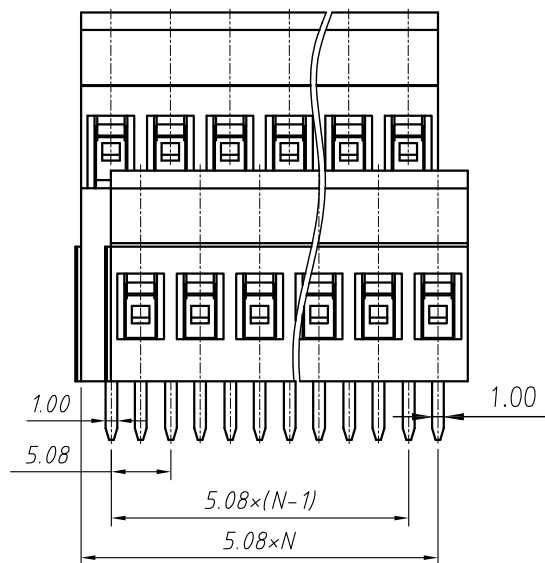

**Material**  
**Housing:** PA66, UL94V-0  
**Clamp:** Brass, Ni plated  
**Pin Header:** Brass, Tin plated  
**Screw:** M3.0, steel Zinc plated

**Electrical**  
**Rated voltage:** 300V  
**Rated current:** 20A  
**Contact Resistance:** 20 mΩ  
**Insulation resistance:** 500MΩ/DC500V  
**Withstand voltage:** AC2000V / 1 min  
**Wire Range:** 26~12AWG 2.5mm<sup>2</sup>

**Mechanical**  
**Temp. Range:** -40 °C ~ +105 °C  
**Strip length:** 6~7mm  
**Torque:** 0.5Nm (4.5Lb.in)

**Order Information**

L-KLS2-130A-5.08-XXP-4S00

RoHS  
Terminal Block  
Pitch  
No. of Pole  
Color: 4- Green  
Screw: S-Slot Screw  
Product Code: 00~99

GENERAL TOLERANCE		ANGLE TOLERANCE		Description:	
X. ±0.60		X. ±5°		Screw CONN TERM Block 5.08mm	
.X ±0.38		.X ±3°		KLS P/N:	KLS2-130A-5.08-XXP-4S
.XX ±0.25		.XX ±2°			
Draw by	2015-09-01	PROJECTION		NingBo KLS ELECTRONIC CO.,L TD.	
Check by	2015-09-15	UNITS	mm		
SCALE		SHEET SIZE	A4		